

1. 概述 INTRODUCTION

微波多层陶瓷天线ANT系列产品设计用于WLAN、WiFi、蓝牙、PHS，手机多频天线, FM 等小体积SMD 片式设计。

Microwave Multi-Layer Ceramic Antenna ANT series are designed to be used in WLAN、WiFi、Bluetooth、PHS、Multiple-band Mobile phone antenna, FM, etc and compact size SMD chip design.

2. 型号 Part Number

ANT 52 H 2450 - A36/S



3. 外型尺寸及测试板焊盘尺寸 Dimensions (Unit: mm)

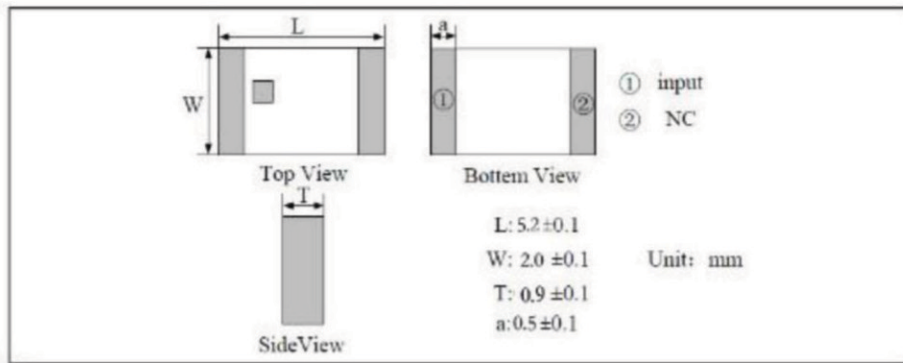

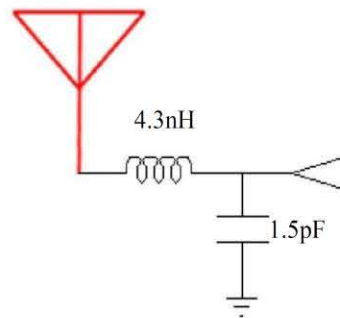
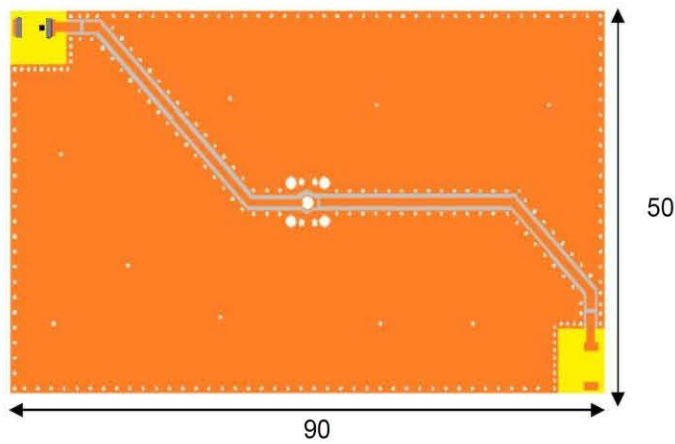
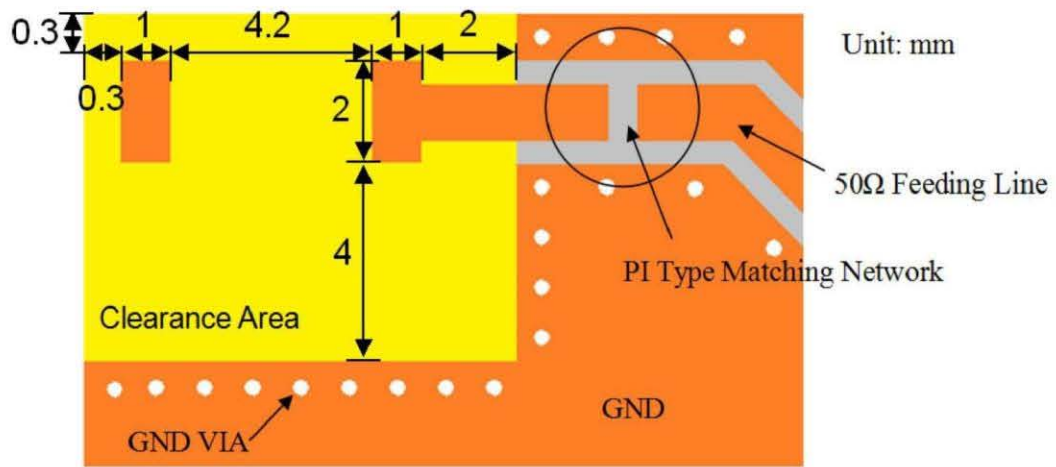

5. 电气性能 Electrical Characteristics

No.	Item (项目)	Specifications (特性)
5.1	Working Central Frequency 中心工作频率	2450 MHz
5.2	Band Width 通带宽度	100MHz typ.
5.3	Peak Gain 峰值增益	4.25 dBi
5.4	V.S.W.R 驻波比	≤2.0
5.5	Polarization 极化方式	Linear 线性
5.6	Azimuth Beam width 方位角	Omni-directional 全向
5.7	Impedance 阻抗	50 Ω

6. 特性曲线 Characteristic curve

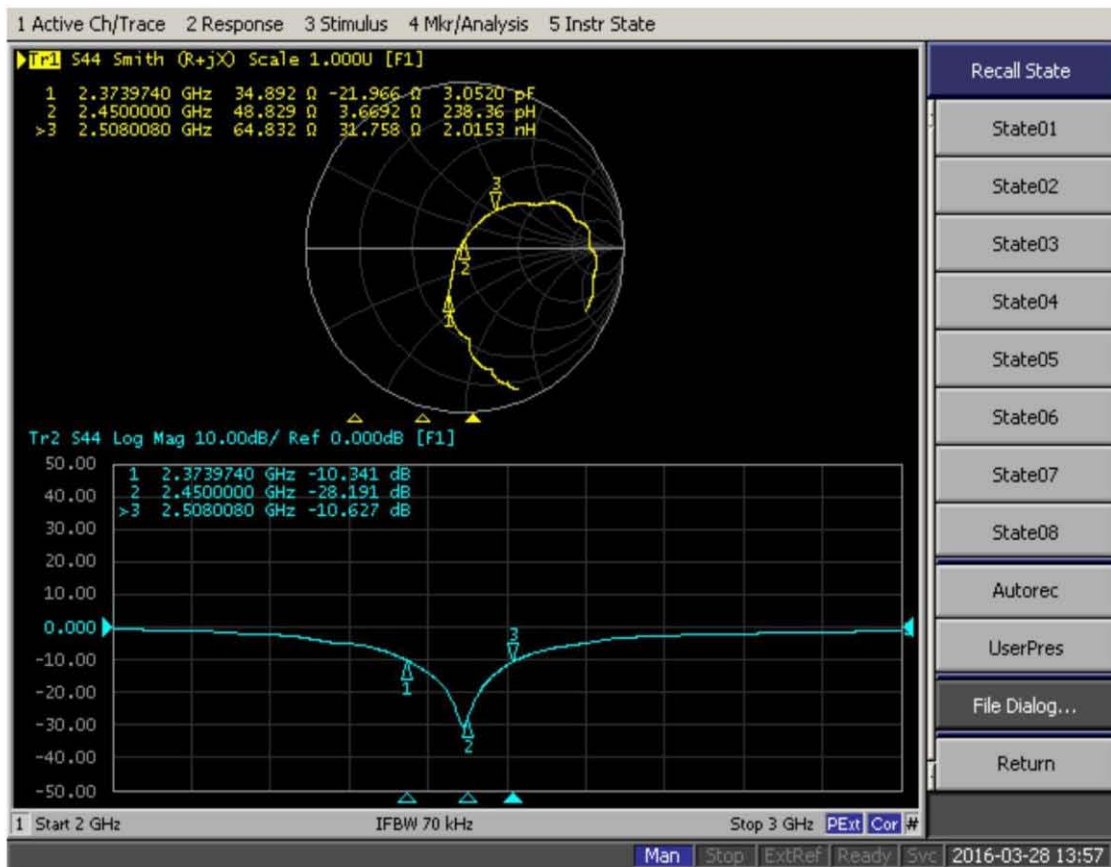

7. 方向图及效率 Radiation Pattern & Efficiency

coordinates:

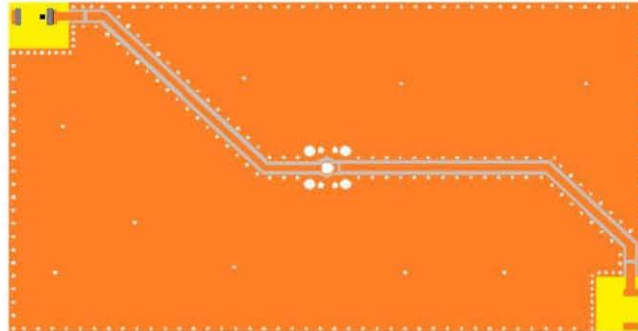
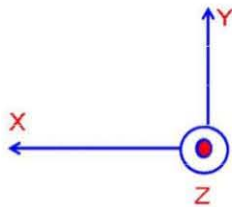

X-Z Plane Plane

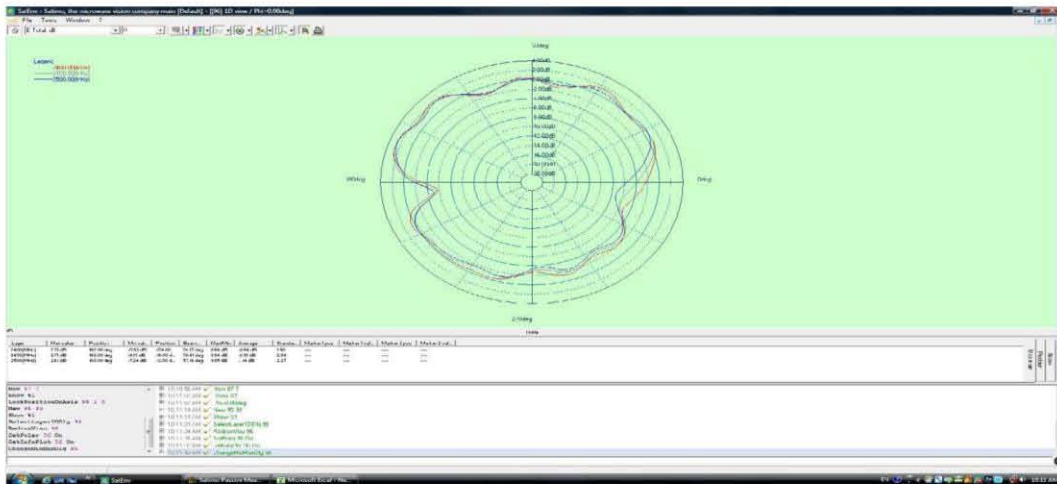

Y-Z Plane

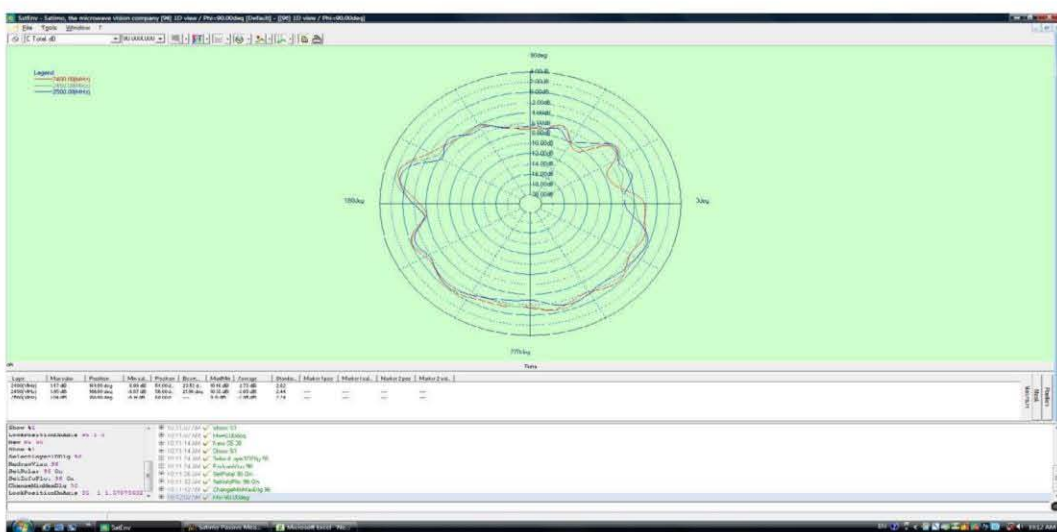

X-Y Plane

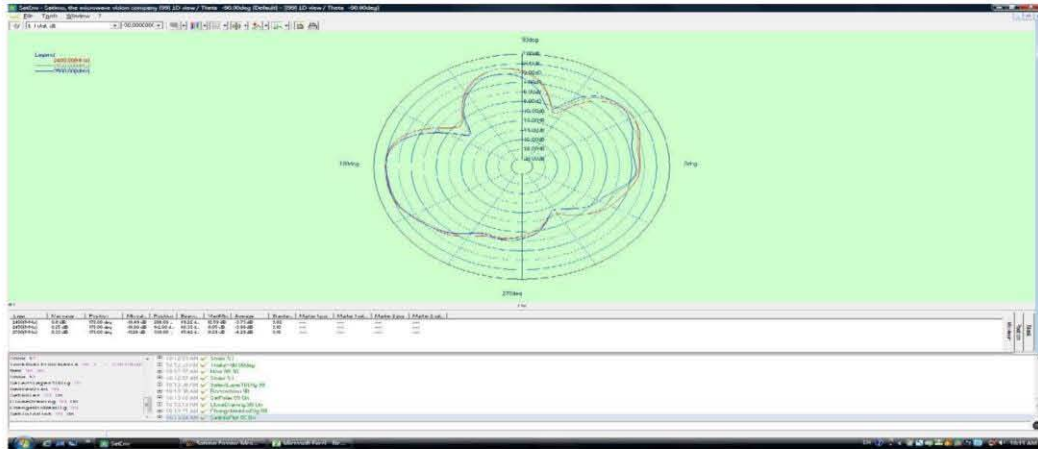

3D Radiation Pattern

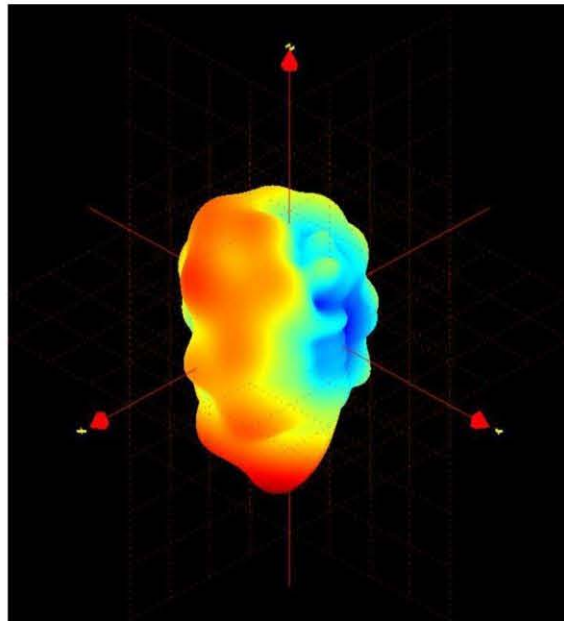

Frequency (MHz)	2400	2450	2500
Avg. Gain (dBi)	-0.64	-0.91	-1.14
Peck Gain (dBi)	3.97	4.25	4.03
Efficiency (%)	71.2	72.5	70.8

8 可靠性试验后允许误差 Post Dependability Tolerance

经可靠性试验后允许比起始读数偏差见下表

Post Dependability Tolerance (Refer to the table)

No.	Item (项目)	Post Dependability Tolerance (可靠性试验后允许附加误差)
8.1	Central Frequency 中心频率	± 5 MHz
8.2	Band Width 通带宽度	± 5 MHz
8.3	Gain 增益	± 0.1 dBi
8.4	V.S.W.R (in BW) 驻波比	± 0.1

9 可靠性试验 Dependability Test

基准条件: 温度范围 Temperature range	$25 \pm 5^{\circ}\text{C}$
相对湿度范围 Relative Humidity range	55~75%RH
工作温度 Operating Temperature range	$-40^{\circ}\text{C} \sim +85^{\circ}\text{C}$
贮藏温度 Storage Temperature range	$-40^{\circ}\text{C} \sim +85^{\circ}\text{C}$

9.1 耐振动 Vibration Resist

在振动频率为10~55Hz 振幅为1.5mm 沿 X.Y.Z 方向各振动2 小时后测试符合表9.1~9.4 规定。

The device should satisfy the electrical characteristics specified in paragraph 9.1~9.4 after applied to the vibration of 10 to 55Hz with amplitude of 1.5mm for 2 hours each in X, Y and Z directions.

9.2 耐跌落冲击 Drop Shock

在 100cm 高度处按 X, Y, Z 三个面分别自由跌落在木制地板上共3 次后测试符合表9.1~9.4 规定。

The device should satisfy the electrical characteristics specified in paragraph 9.1~9.4 after dropping onto the hard wooden board from the height of 100cm for 3 times each facet of the 3 dimensions of the device.

9.3 耐焊接热 Solder Heat Proof

能承受经120~150°C的温度预热120 秒后, 在255°C+10°C的焊锡浸5±0.5 秒, 或300°C-10°C的电烙铁焊接3±0.5 秒, 焊接面无损伤。

The device should be satisfied after preheating at 120°C~150°C for 120 seconds and dipping in soldering Sn at 255°C+10°C for 5±0.5 seconds, or electric iron 300°C-10°C for 3±0.5 seconds, without damage.

9.4 结合力试验 Tensile Strength of Terminal

在产品电极端子上或表面上应能承受1kg垂直拉力10±1秒。

The device should not be broken after tensile force of 1.0kg is slowly applied to pull a lead pin of the fixed device in the lead axis direction for 10±1 seconds.

9.5 耐弯曲试验 Bending Resist Test

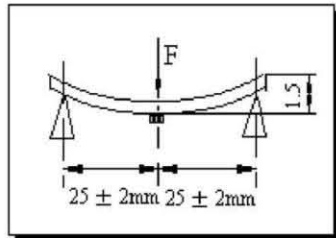

将产品按图焊在 $1.6\pm 0.2\text{mm}$ 的PCB板中间,由箭头方向施力: 1mm/S ,弯曲距离: 1.5mm ,保持 $5\pm 1\text{S}$,产品金属层无脱落。

Weld the product to the center part of the PCB with the thickness $1.6\pm 0.2\text{mm}$ as the illustration shows, and keep exerting force arrow-ward on it at speed of 1mm/S , and hold for $5\pm 1\text{S}$ at the position of 1.5mm bending distance, so far, any peeling off of the

product metal coating should not be detected.

在温度为 $60\pm 2^\circ\text{C}$,相对湿度90~95%的恒温湿箱中放置96小时,在常温中恢复1~2小时后测试,符合表9.1~9.4规定。

The device should satisfy the electrical characteristics specified in paragraph 9.1~9.4 after exposed to the temperature $60\pm 2^\circ\text{C}$ and the relative humidity 90~95% RH for 96 hours and 1~2 hours recovery time under normal condition.

9.7 高温特性 High Temperature Endurance

在温度为 $85\pm 5^\circ\text{C}$ 的恒温箱中放置 96 ± 2 小时,在常温中恢复1~2小时后测试。符合表9.1~9.4规定。

The device should satisfy the electrical characteristics specified in paragraph 9.1~9.4 after exposed to temperature $85\pm 5^\circ\text{C}$ for 96 ± 2 hours and 1~2 hours recovery time under normal temperature.

9.8 低温特性

在温度为 $-40^\circ\text{C}\pm 5^\circ\text{C}$ 低温箱中放置 96 ± 2 小时后恢复1~2小时测试符合表9.1~9.4规定。

The device should also satisfy the electrical characteristics specified in paragraph 9.1~9.4 after exposed to the temperature $-40^\circ\text{C}\pm 5^\circ\text{C}$ for 96 ± 2 hours and to 2 hours recovery time under normal temperature.

9.9 温度循环 Temperature Cycle Test

在 -40°C 温度中保持30分钟,再在 $+85^\circ\text{C}$ 温度中保持30分钟,共循环5次后在常温中恢复1~2小时后测试符合表9.1~9.4规定。

The device should also satisfy the electrical characteristics specified in paragraph 9.1~9.4 after exposed to the low temperature -40°C and high temperature $+85^\circ\text{C}$ for 30 ± 2 min each by 5 cycles and 1 to 2 hours recovery time under normal temperature.

10 回流焊温度 Reflow Soldering Standard Condition

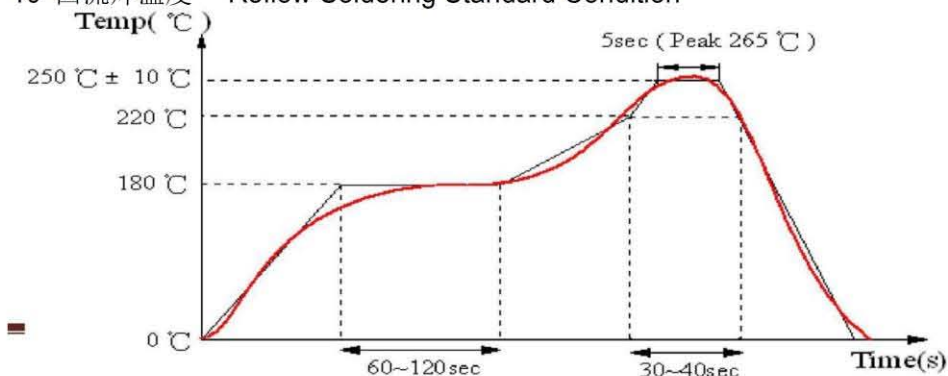

11 包装尺寸(5220) Packaging and Dimensions

11.1 Plastic Tape

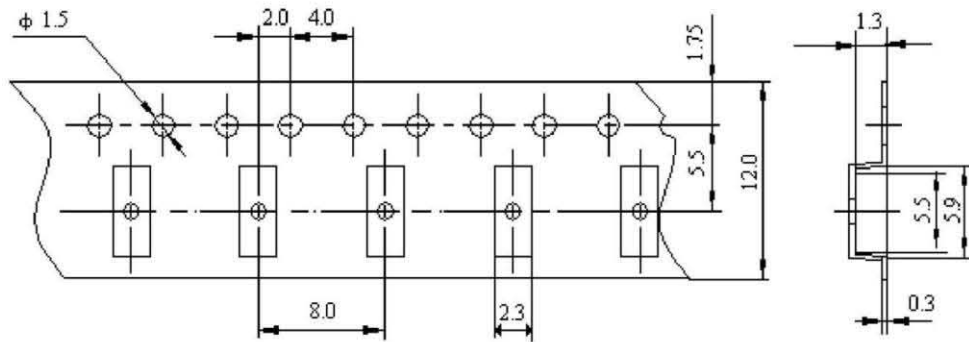

包装说明: Remarks for Package

载带尾部空穴长度150~200mm, 载带头部空穴长度250~300mm, 头部的盖带加长250mm。

Reserve a length of 150~200mm for the trailer of the carrier and 250~300 mm for the leader of the carrier and further 250mm of cover tape at the leading part of the carrier.

11.2 Reel (1000 pcs/Reel)

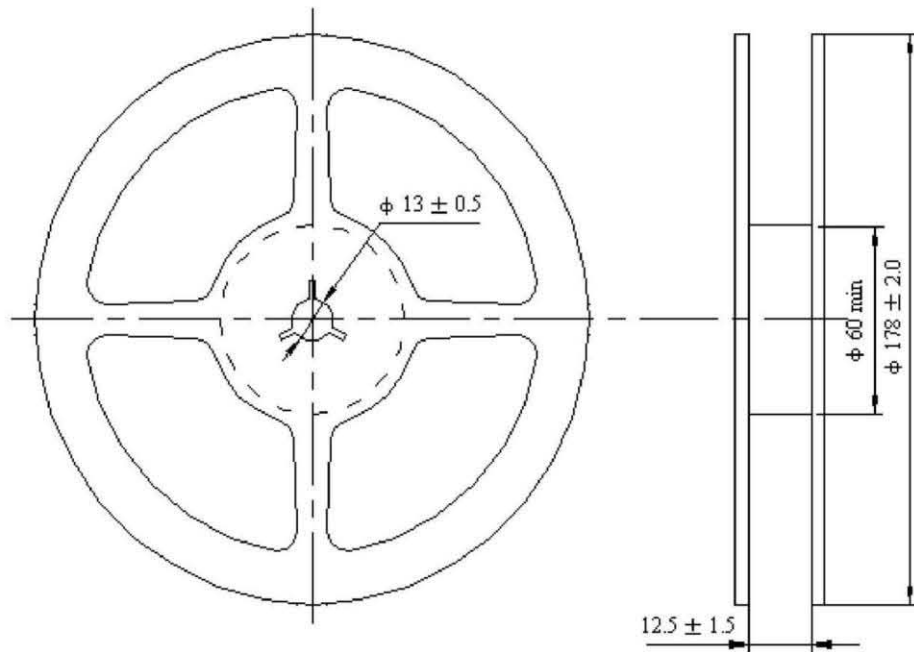

11.3 储存条件 Storage Period

易氧化产品, 产品拆封后请于48小时内用完或重新密封包装!

Oxidizable. material, please repack within 48 hours by re-seal the package treatment after use them!

CHIP ANTENNA

Multilayer Chip Type

Small Size • Low Loss • High Reliability

Simplify Circuit Design & Tuning



PHONE



PDA

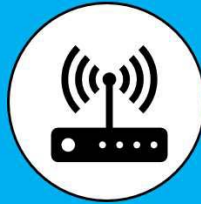

RF DEVICE

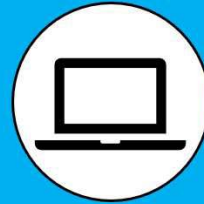

NOTEBOOK

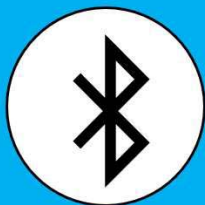

BLUETOOTH



WLAN



GPS



DVD

CHIP ANTENNA

Product Structure

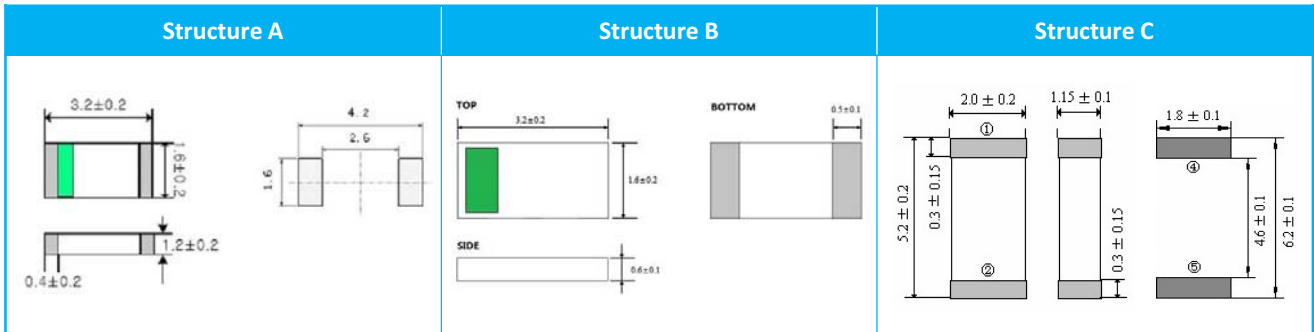

Dimension & Electrical Specification

Shinhom P/N	Structure	Size (mm)			Freq. Range (MHz)	Gain (dBi)	VSWR (Max.)	Impedance (Ω)	Polarization	Azimuth Beam Width (MHz)
		L	W	T						
ANT3216H2450-A02	A	3.2 ± 0.2	1.6 ± 0.2	1.2 ± 0.2	2400~2500	0~2	≤2.0	50	Linear	Omni-directional
ANT3216H2450-A09S	B	3.2 ± 0.2	1.6 ± 0.2	0.6 ± 0.1	2400~2484	2 (Typ.)	≤2.0	50	Linear	Omni-directional
ANT5220H2450-A04	C	5.2 ± 0.2	2.0 ± 0.2	1.15 ± 0.1	2375~2525	0~2	≤2.0	50	Linear	Omni-directional

Electrical Characteristics

Shinhom P/N	Test board	Characteristics	Radiation Pattern		
			XY-V/XY-H	XZ-V/XZ-H	YZ-V/YZ-H
ANT3216H2450-A02					
ANT3216H2450-A09S					
ANT5220H2450-A04					